



A 5th order video band elliptic filter topology using OTRA based Fleischer Tow Biquad with MOS-C Realization

Ahmet Gökçen^{1*}, Uğur Çam²

¹Faculty of Electrical and Electronics, Department of Electrical and Electronics Engineering, University of Iskenderun Technical, 31220 Iskenderun, Hatay, Turkey

²Department of Electrical and Electronics Engineering, Faculty of Engineering, Dokuz Eylül University, İzmir, Turkey

Abstract

A new 5th order video band elliptic filter topology is presented. In video applications high order elliptic filters were used. The proposed 5th order lowpass filter was simulated with PSPICE simulation program. The elliptic filter configuration consists of two cascade connected lowpass notch filters and a lowpass filter which is obtained using Operational Transresistance Amplifier (OTRA) based Fleischer Tow biquad. After designing the 5th order video band elliptic filter topology, the MOS-C realization is obtained and used in PSPICE simulation.

Keywords:

Operational Transresistance Amplifier, Video filter applications, High order elliptic filters

Article history:

Received 27 March 2016, Accepted 04 May 2016, Available online 10 May 2016

Introduction

Active filters employing single active element are especially useful for applications where the power consumption is an important design constraint. Several voltage mode filters that use an active element rather than operational amplifier have been developed (Horng *et al.*, 1997; Liu and Lee, 1996; Salama and Soliman, 2000; Liu *et al.*, 1993; Liu and Tsao, 1991) to

^{1*} Corresponding Author :Ahmet Gökçen, email: ahmetgkcn@gmail.com

overcome well-known op-amp limitations such as constant gain-bandwidth product, low slew rate, etc. The internally grounded and current differencing input terminals of OTRA make MOS-C realization possible. In other words, the resistors connected to the input terminals of OTRA can easily be implemented using MOS transistors with complete nonlinearity cancellation (Salama and Soliman, 1999). The resulting circuit will consist of only MOS transistors and capacitors. This will save a significant amount of chip area and lead to circuits that are electronically tunable. That is, the resistance values and hence the related filter parameters can be adjusted by simply changing the bias (gate) voltages.

A literature survey shows that both Kerwin-Huelsman-Newcomb (KHN) and Tow-Thomas (TT) biquads have been implemented using current conveyors, OTRAs, and OTAs (Kerwin et al., 1967; Thomas, 1968; Senani and Singh, 1995; Soliman, 1994; Shah and Bhaskar, 2002; Soliman, 2007; Soliman, 2008; Koton et al., 2010.) However, the Fleischer-Tow biquad, which is an improved version of the Tow-Thomas configuration, offers the realization of all 5 different second-order filtering functions, namely low-pass, high-pass, band-pass, notch, and all-pass (Gökçen et al., 2010).

In this study, an OTRA-based Fleischer-Tow biquad, which uses 2 capacitors, is presented for the realization of 5th order video band elliptic filter. Therefore, the realized filter is canonical in the number of capacitors and occupy less area on the chip. Additionally, the resonant frequency and quality factor of the filters can be controlled independently. All of the resistors used in the filters were realized by MOS transistors. The resultant MOS-C implementation of the OTRA-based Fleischer-Tow biquad is suitable for full integration.

Operational Transresistance Amplifier

OTRA is a high gain current input, voltage output device. The circuit symbol of the OTRA is illustrated in Figure 1.

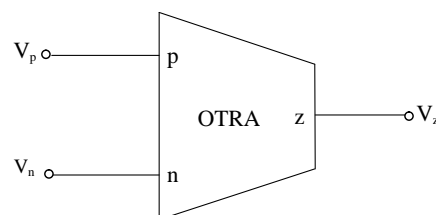

Figure 1 Circuit symbol of the OTRA

The operation of the OTRA can be characterized by the following equations;

$$V_z = R_m (I_p - I_n)$$

$$V_p = V_n = 0$$
(1)

The OTRA, which is known also as current differencing amplifier or Norton amplifier, is an important active element in analog ICs and systems. Both input and output terminals of OTRA are characterized by low impedance, thereby eliminating response limitations incurred by capacitive time constants. Since the input terminals of OTRA are at ground potential, most effects of parasitic capacitances and resistances disappear. The output terminal of OTRA exhibits low impedance so that OTRA based voltage mode circuits can easily be cascaded without additional buffers. For ideal operation, the transresistance R_m approaches infinity forcing the input currents to be equal. Thus, the OTRA must be used in a feedback configuration in a way that is similar to the classical op-amp (Salama and Soliman, 1999).

OTRA has the advantages of high slew rate and wide bandwidth due to the fact that it benefits from the current processing capabilities at the input terminals. On the other hand, since its output terminal is characterized as low impedance, OTRA is suitable for voltage mode operations keeping the compatibility with existing signal processing circuits (Salama and Soliman, 1999).

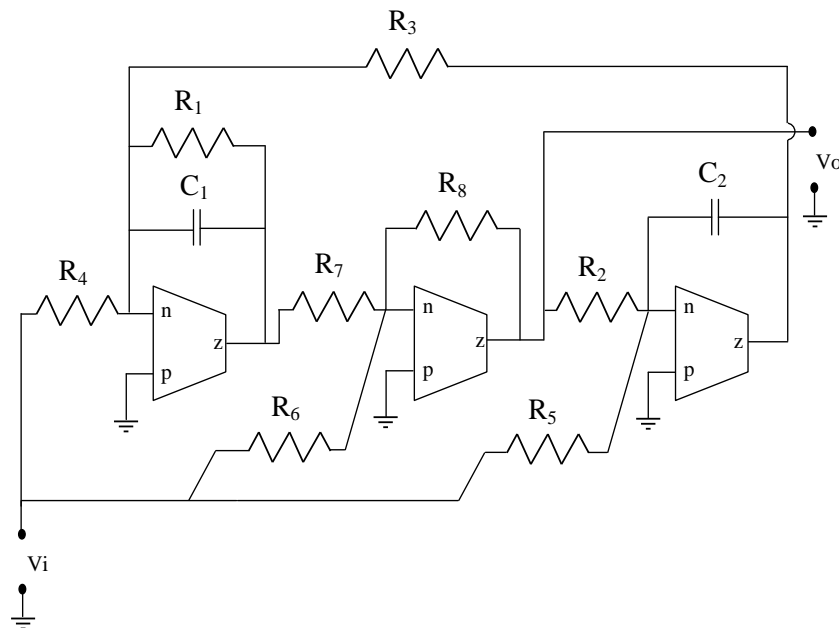

Figure 2 OTRA-RC based realization of the Fleischer-Tow Biquad

The OTRA-RC based realization of the Fleischer-Tow Biquad is shown in Figure 2 (Gökçen *et al.*, 2007; Gökçen and Çam 2009). Routine analysis yields the transfer function as;

$$\frac{V_o}{V_i} = - \frac{\frac{R_8}{R_6} s^2 + \frac{1}{R_1 C_1} \left(\frac{R_8}{R_6} - \frac{R_1 R_8}{R_4 R_7} \right) s + \frac{R_8}{R_3 R_5 R_7 C_1 C_2}}{s^2 + \frac{1}{R_1 C_1} s + \frac{1}{R_2 R_3 C_1 C_2} \cdot \frac{R_8}{R_7}} \quad (2)$$

With proper selection of admittances in Equation (2), voltage mode second order lowpass (LP), highpass (HP), bandpass (BP) and notch filters can be realized(Gökçen, 2010).

MOS-C Realization

The OTRA is suitable for nonlinearity cancellation, as the two input terminals are virtually grounded. Assume that the two NMOS transistors, M_1 and M_2 , shown in Figure 3, are matched and operating in the triode region. Since the transistors M_1 and M_2 have equal drain and source voltages, both even and odd nonlinearities are cancelled (Salama and Soliman, 1999). Note that the equivalent resistance value, which appears between negative input terminal and output terminal of OTRA, is given as

$$R = \frac{1}{\mu_n C_{ox} (W/L) (V_a - V_b)} \quad (3)$$

where V_a and V_b are the gate voltages.

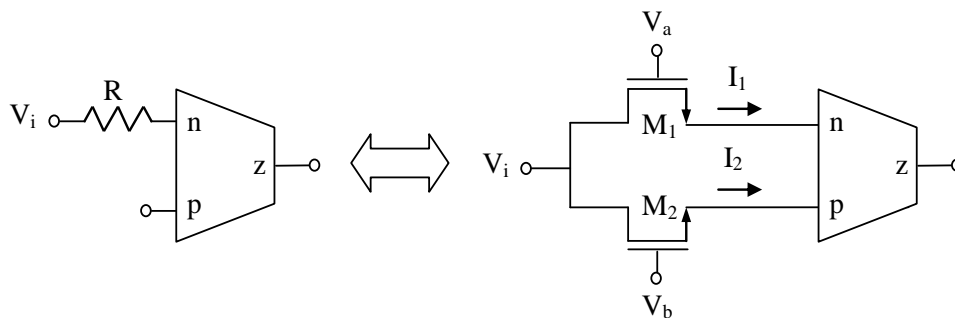

Figure 3 Realizing the resistor connected to the input terminal of OTRA with MOS transistors

Video Filter Application

The elliptic filter configuration consists of two cascade connected lowpass notch filters and a lowpass filter which are obtained using OTRA based Fleischer Tow biquad by proper selection of resistors. After designing the 5th order video band elliptic filter topology, the MOS-C realization is obtained and used in PSPICE simulation.

Block diagram of the 5th order elliptic video filter is given in Figure 4.

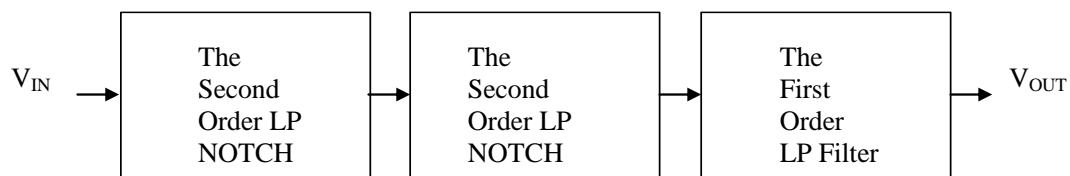

Figure 4 Block diagram of proposed fifth order video filter

By replacing each resistor in Figure 2 with the MOS implementation of Figure 3, the fully integrated realization of Fleischer-Tow biquad shown in Figure 5 has been obtained. The resistor values can be calculated by using Equation (3). It is easy to show that each resistor in Figure 3 can be electronically controlled with an external voltage. Thus, the quality factor can be adjusted electronically without disturbing the resonant frequency with an external control voltage (Gökçen, 2010).

The MOS-C realization of the OTRA based Fleischer Tow biquad topology is shown in Figure 5.

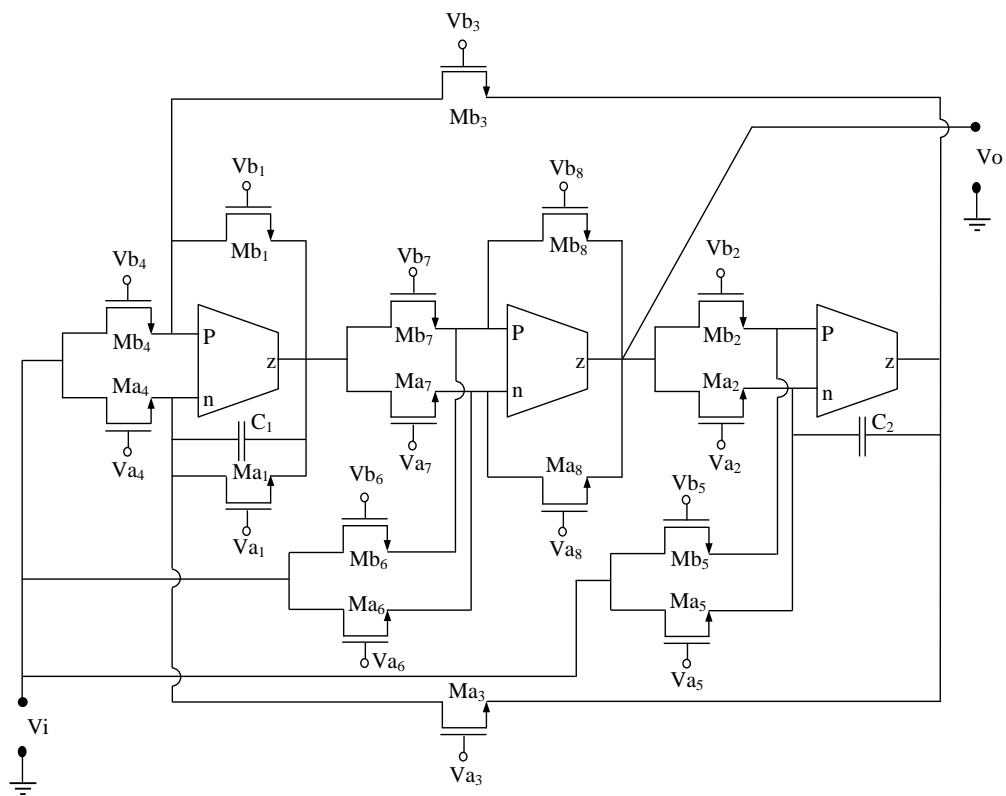

Figure 5 MOS-C realization of the OTRA based Fleischer Tow biquad

The first order lowpass filter topology is also shown in Figure 6.

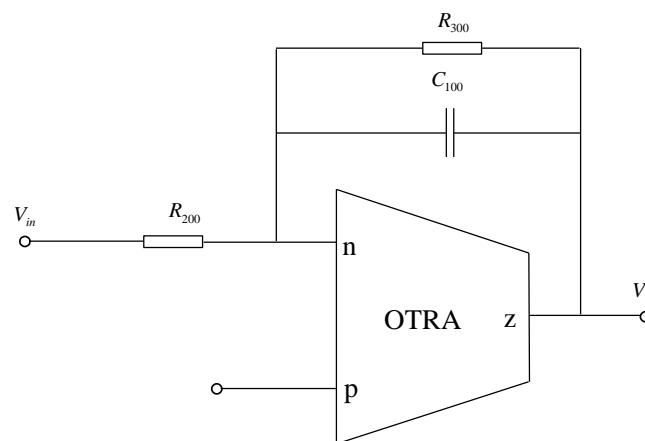

Figure 6 Voltage mode first order Lowpass filter

Simulation Results

Video filter is designed to pass the signals of frequencies up to 5 MHz and sharply suppress the signals beyond this frequency.

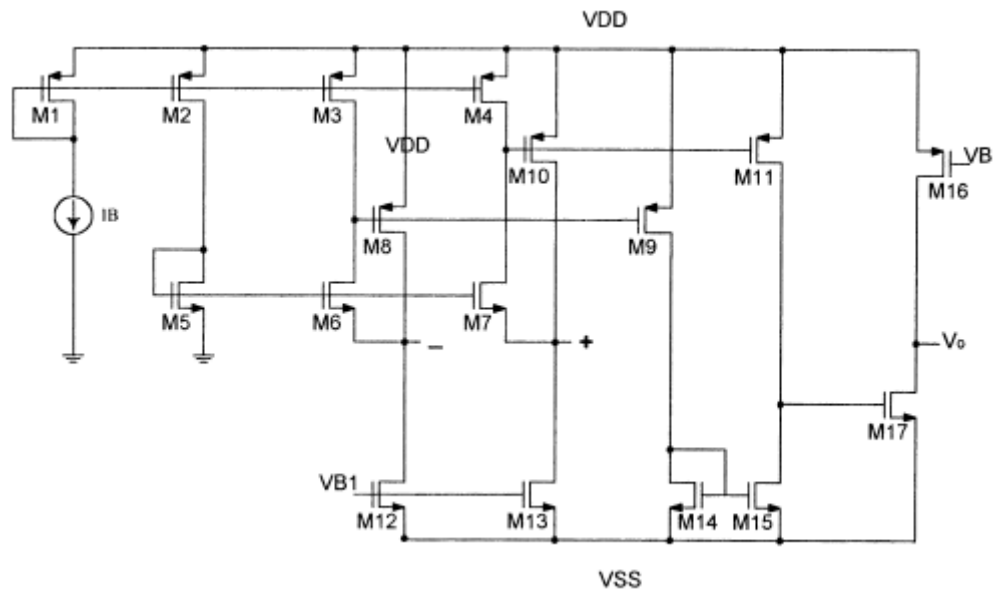

Figure 8. CMOS realization of OTRA (Salama and Soliman, 1999)

To verify the theoretical study, filter was simulated with the PSPICE simulation program. In the simulations, a CMOS realization of OTRA (Salama and Soliman, 1999), which is shown in Figure 8, was used with the same transistor aspect ratios as in (Salama and Soliman, 1999). Supply voltages were taken as $V_{DD} = 2.5$ V and $V_{SS} = -2.5$ V.

In the simulation, 0.35 μm TSMC technology parameters were used. According to this parameter set, gate oxide thickness is given as $T_{ox} = 7.9 \times 10^{-9}$ m. Since the oxide dielectric constant is $\epsilon_{ox} = 3.46 \times 10^{-11}$ F/m, oxide capacitance is found as $C_{ox} = \epsilon_{ox} / T_{ox} = 4.38 \times 10^{-3}$ F. Electron mobility, μ_n was 675.4 $\text{cm}^2 / \text{V}\cdot\text{s}$ for TSMC 0.35 μm technology.

The resistors are implemented via MOS transistors as mentioned above. The resistor values correspond to $R_1=35\text{k}\Omega$, $R_2=25\text{k}\Omega$, $R_3=5\text{k}\Omega$, $R_4=20\text{k}\Omega$, $R_5=5\text{k}\Omega$, $R_6=5\text{k}\Omega$, $R_7=5\text{k}\Omega$, $R_8=5\text{k}\Omega$, $C_1=4.5\text{pF}$, $C_2=4.5\text{pF}$ (for the first lowpass notch); $R_{10}=5.2\text{k}\Omega$, $R_{20}=10\text{k}\Omega$, $R_{30}=10\text{k}\Omega$, $R_{40}=5.2\text{k}\Omega$, $R_{50}=4.8\text{k}\Omega$, $R_{60}=5\text{k}\Omega$, $R_{70}=5\text{k}\Omega$, $R_{80}=5\text{k}\Omega$, $C_{10}=4.5\text{pF}$, $C_{20}=4.5\text{pF}$ (for the second lowpass notch); $R_{200}=2.6\text{k}\Omega$, $R_{300}=2.4\text{k}\Omega$, $C_{100}=21\text{pF}$ (for the last lowpass)(Gökçen, 2010). The simulated output voltage of the 5th order elliptic lowpass filter is shown in Figure 9.

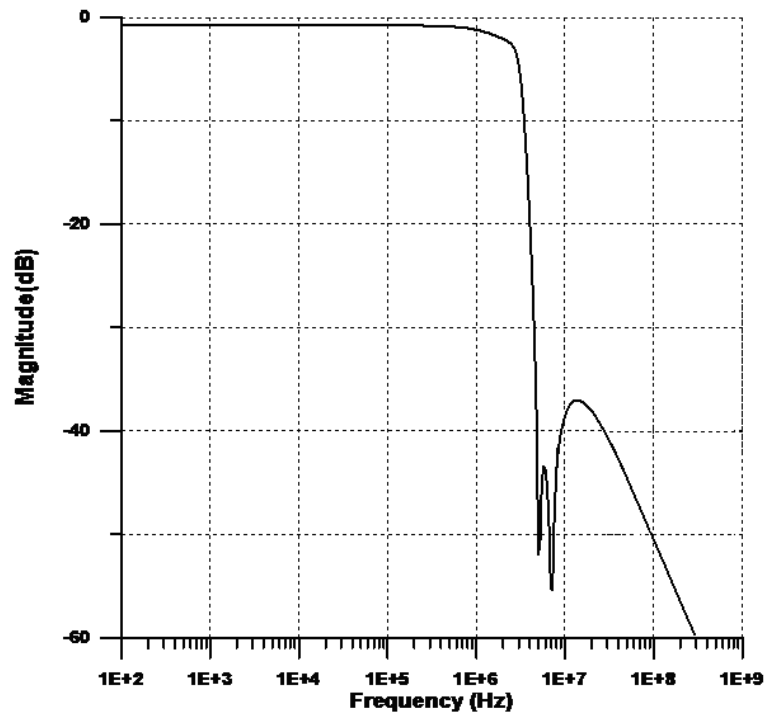

Figure 9 Gain response of the proposed filter

The time step response of the proposed video filter topology is shown in Figure 10.

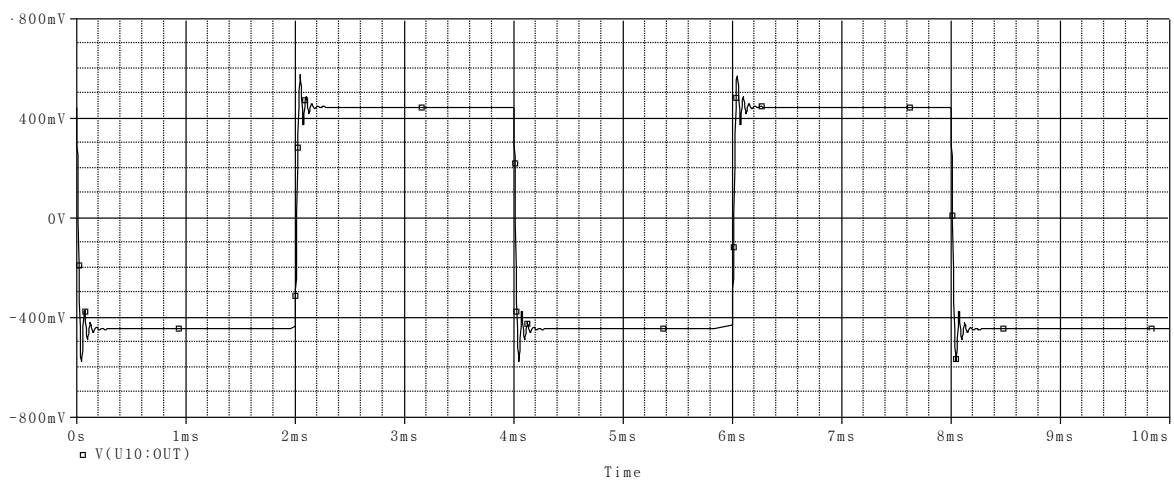

Figure 10 Time step response of the proposed filter

References

- Fleischer, P.E., Tow, J., "Design formulas for biquad active filters using three operational amplifiers", Proceedings of the IEEE, Proceeding Letters, Vol. 61, pp. 662-663, 1973.
- Gökçen, A., Kılınç, S., & Çam, U. 2007. Tek OTRA Kullanılarak Tümlestirmeye Uygun İkinci Derece Analog Süzgeç Tasarımları. IEEE 15th Signal Processing and Communications Applications Conference (SIU2007), Eskisehir / Turkey, 11-13 June 2007.

- Gökçen, A. & Çam, U. 2009a. MOS-C Single Amplifier Biquad Using the Operational Transresistance Amplifier. *International Journal of Electronics and Communications. (AEÜ)*, 63, 660–664.
- Gökçen, A., Kılınc, S., & Çam, U. 2010. Fully Integrated Universal Biquads Using Operational Transresistance Amplifiers with MOS-C Realization. *Turkish Journal of Electrical Engineering & Computer Science*, vol.19,no:3, 2011.
- Gökçen, 2010. “New Possibilities in The Design of Analog Integrated Circuit with MOS-C Realization”, Phd Thesis, Graduate School of Natural and Applied Sciences, Dokuz Eylül University, İzmir, Turkey, June, 2010.
- Hornig, J. W., Lay, J. R., Chang, C. W., Lee, M. H. 1997. High input impedance voltage-mode multifunction filters using plus-type CCII. *Electronics Letters*, 33, 472–475.
- Kerwin, W., Huelsman, L., Newcomb, R., “State variable synthesis for insensitive integrated circuit transfer functions”, *IEEE J. Solid State Circuits*, Vol. 2, pp. 87-92, 1967.
- Koton, J., Herencsar, N., Vrba, K., “KHN-equivalent voltage-mode filters using universal voltage conveyors”, *International Journal Electron. Commun. (AEU)*, doi:10.1016/j.aeue.2010.02.005, 2010.
- Liu, S. I., & Lee, J. L. 1996. Insensitive current/voltage-mode filters using FTFNs. *Electronics Letters*, (32), 1079–1080.
- Salama, K. N., & Soliman, A. M. 2000. Active RC applications of the operational transresistance amplifier. *Frequenz Journal*, 54, 171–176.
- Liu, S. I., Chen, J. J., Tsao, H. W., & Tsay, J. H. 1993. Design of biquad filters with a single current follower. *IEE Proceedings Circuits Devices Systems*, (140),165-170.
- Liu, S. I., & Tsao, H. W. 1991. The single CCII biquads with high-input impedance. *IEEE Transactions on Circuit and Systems*, 38, 456–461.
- Salama, K. N., & Soliman, A. M. 1999. CMOS operational transresistance amplifier for analog signal processing applications. *Microelectronics Journal*, 30, 235-245.
- Senani, R., Singh, V.K., “KHN-equivalent biquad using current conveyors”, *Electronics Letters*, Vol. 31, pp. 626-628,1995.
- Shah, S., Bhaskar, D.R., “Design of KHN biquad using operational transconductance amplifier”, *The 2002 45th Midwest Symposium on Circuit and Systems*, Vol. 1, pp. 48-51, 2002.
- Soliman, A.M., “Kerwin-Huelsman-Newcomb circuit using current conveyors”, *Electronics Letters*, Vol. 30, 2019-2020, 1994.
- Soliman, A.M., “Voltage mode and current mode Tow Thomas biquadratic filters using ICCII”, *International Journal of Circuit Theory and Applications*, Vol. 35, pp. 463-467, 2007.
- Soliman, A.M., “Kerwin-Huelsman-Newcomb circuit using inverting current conveyors”, *Journal of Active and Passive Electronic Devices*, Vol. 3, pp. 273-279, 2008.
- Thomas, L.C., “The biquad: Part – Some practical design considerations”, *IEEE Trans. Circuit Theory*, Vol. CT-18, pp. 350-257, 1971.
- Tow J., “Active RC filters – A state-space realization”, *Proceedings of the IEEE, Proceeding Letters*, Vol. 56, pp.1137-1139, 1968.